

The making of a TIPSY KEY

© John Wilding, UK
jwilding@clocksmagazine.com

A tipsy key is one that will only wind in one direction. It is used on quality clocks and chronometers and this one was made for my month-going regulator which, because of the extra wheel in the train, winds anticlockwise. A tipsy key acts as a safety device as the winder is unable to turn the key the wrong way. It is quite amazing the number of movements I have come across where the winding arbor has been subjected to so much force in attempting to turn the key the wrong way that the square is actually bent.

I have to confess that I had not seen one of these keys dismantled and when I was discussing my month-going regulator with David Poole FBHI, the Master of the Clockmakers Company, he asked me if I was going to make a tipsy key for it and I had to confess that I hadn't seen one close up so he very kindly sent me a photograph of one that he had made for one of his clocks and for which I am most grateful. The photograph was of the key dismantled and gave me all the information necessary for making one.

As can be seen from the various pictures and the drawing, **figure 1**, the key pipe is split into two parts each having a ratchet formed at the inner ends where they abut. A spring is fitted to keep the two parts together but if the key is turned the wrong way the spring will be overridden and the key will just click round without doing any damage to the clock. Here I have fitted a bow as the key handle but it could quite easily be made as a crank key.

The drawing gives suggested dimensions, but these will depend on the size of the winding square and the diameter of the hole in the dial if there is one.

Construction

The key disassembled is shown in **figure 2** where you can see that it consists of three parts plus a spring and a short locating pin. The pipe can be made first. This is from $\frac{3}{16}$ in brass bar. A length is held in the three-jaw chuck with some 2in extending from the chuck jaws. This is reduced to .280in as depicted on the drawing. The work

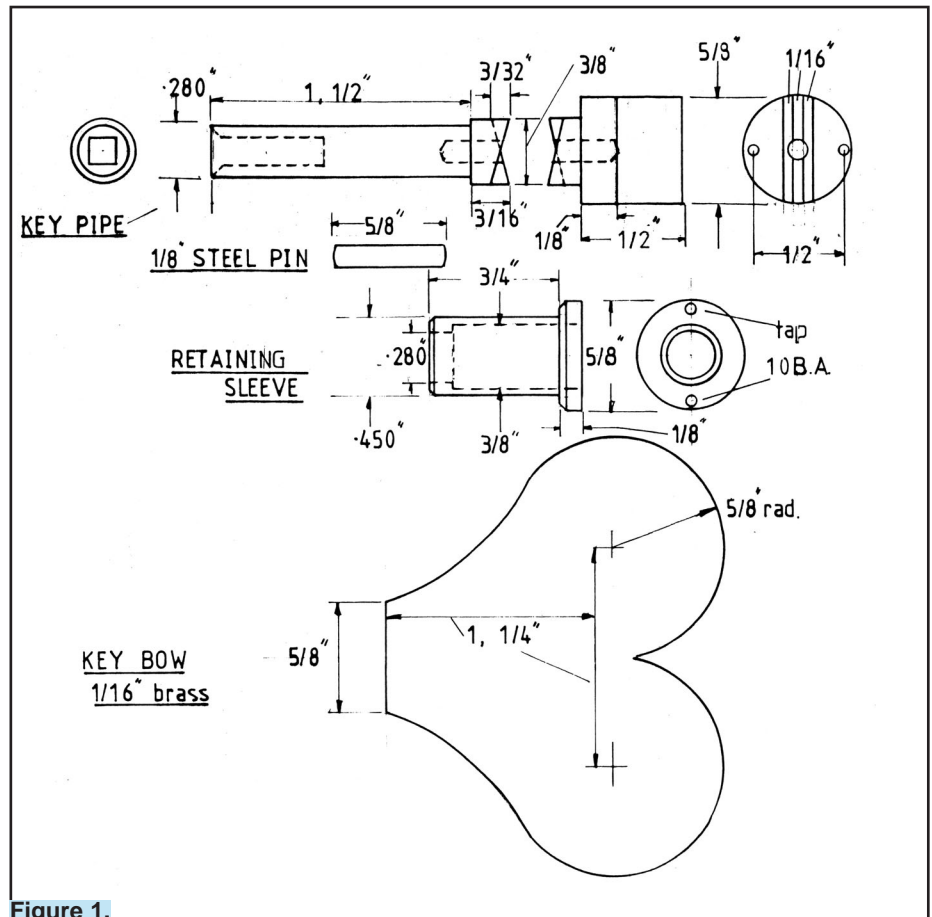

Figure 1.

Figure 2. The tipsy key dismantled.

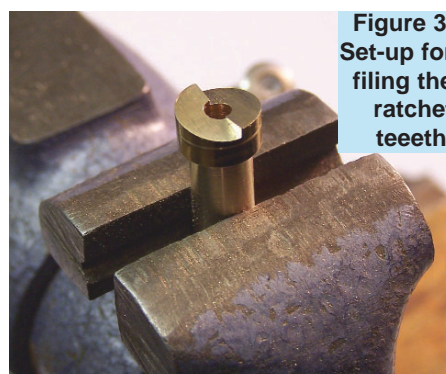
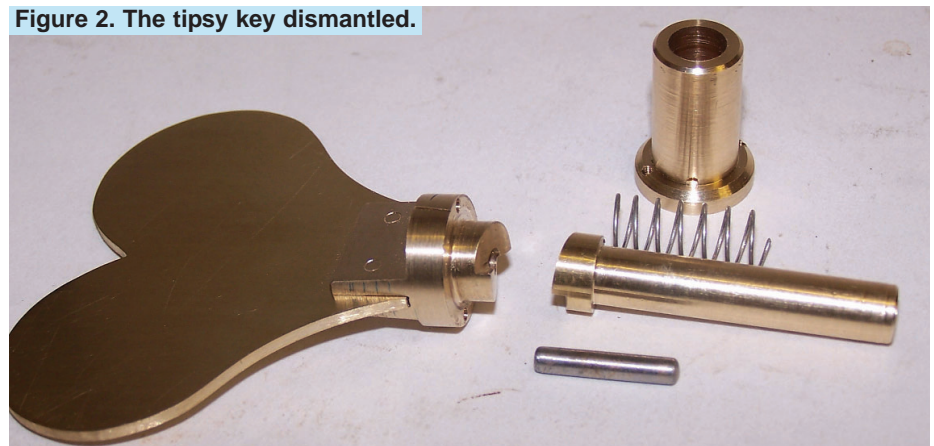

Figure 3. Set-up for filing the ratchet teeth.

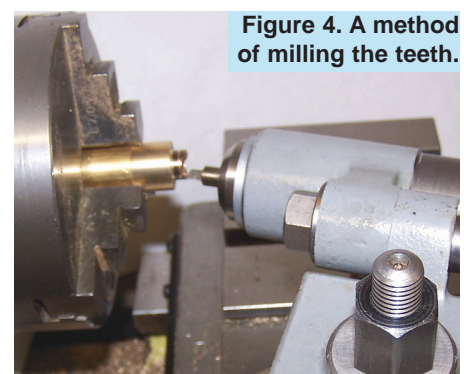

Figure 4. A method of milling the teeth.